



Installation Manual

AdvanTex[®] **AX20 Treatment Systems** *Residential Applications*

Orenco[®]
Orenco Systems, Incorporated

1-800-348-9843
+1-541-459-4449

www.orenco.com

How To Use This Manual	Page 2
Before You Begin	Page 3
Septic Tanks Used in AX20 Treatment Systems	Page 3
Standard System Components	Page 4
Installation Overview	Page 5
Installation Steps	Page 5
Step 1: Review or Sketch Site Plan	Page 6
Step 2: Make Excavation(s)	Page 7
Step 3: Prep and Set Septic Tank and Pump Basin	Page 8
Step 4: Install Tank Adapters and Risers (If Needed)	Page 9
Step 5: Test Tank and Adapter Seams for Watertightness	Page 9
Step 6: Prep and Set AX20 Unit	Page 10
Step 7: Install Pump Package in Septic Tank	Page 11
Step 8: Install Pump Package in Pump Basin	Page 11
Step 9: Install Recirculating Splitter Valve (RSV)	Page 12
Step 10: Connect Filtrate Return Line	Page 12
Step 11: Connect Recirc Transport Line	Page 12
Step 12: Connect Filtrate Discharge Line	Page 13
Step 13: Install Passive Air Vent	Page 13
Step 14: Mount and Wire Control Panel	Page 13
Step 15: Perform Operational Test	Page 14
Step 16: Backfill Installation	Page 15

How To Use This Manual

This manual contains an Installation Overview and a set of Installation Steps.

- **Installation Overview** — This is a simple overview of the installation steps. It is a reference only; complete instructions are found in the installation steps that follow.
- **Installation Steps** — This provides general instructions for each installation step, along with references to installation documents for specific components. There are also steps in this manual covering operations performed before and after the AX20 unit is installed that are necessary to successfully complete the installation. Many Orenco products come with installation instructions. All of these instructions are also provided in hardcopy form in our Orenco Installer Binder. Contact your Distributor or Orenco for a copy of the binder, or find individual instructions online in the Orenco Document Library at www.orenco.com.

You will find *IMPORTANT information*, *Key Points*, and *Notes* in this manual, marked with easy-to-see visuals:



IMPORTANT — These point out potential hazards to equipment or people during and after the installation.



Key Points — These are critical for a quality installation and must be completed in order for your installation to be successful.



Notes — These cover useful information and tips that can help make your installation simpler or easier. They may also provide information on variations in components or methods.

Before You Begin

Before you begin the installation, read this manual and any documents referenced in it. Also, be sure that the instructions for these products are the most current ones available. Please note that **you must perform the installation according to the current manual or the AdvanTex® Treatment Systems Limited Warranty will be void.** You can make sure your instructions are current by checking our online Document Library at www.orenco.com. You'll save time and money on installation day, and you'll get fewer call-backs.

This manual provides basic information for installing AdvanTex™ AX20 treatment systems. It does not replace training or engineering plans. If there are differences between your engineering plans and the instructions in this manual, contact your Designer or your local Dealer of Orenco Residential Wastewater Treatment Systems.

If you are not an Authorized AdvanTex Installer, contact your local Dealer for training and authorization before installing this system. The Dealer can provide technical support, training, and replacement components. To find the nearest Dealer, check the Distributor Locator page at www.orenco.com. If there is no local Dealer, call Orenco Systems, Inc. at (800) 348-9843 or +1 (541) 459-4449.



IMPORTANT:

- *The backwash discharge from a salt-type water softener MUST NOT be plumbed into an AX20 unit or the preceding septic tank.*
- *Failing to follow these instructions will void the system's warranty.*
- *Contact your Dealer if you have questions about any household plumbing arrangements that may interfere with the functioning of the system.*



Key Points:

- Inspect your order for completeness and inspect each component for shipping damage. If any of the order is incomplete or damaged, contact your Dealer or Orenco.
- Check to be sure instructions and items supplied comply with your state and local regulations.
- Carefully read and follow all instructions.
- If you are not an authorized AdvanTex Installer, contact your local Dealer for training and authorization before installing this system.



Note: *All pipe diameters provided are U.S. nominal IPS pipe sizes. If you are using metric pipe, you may need adapters to connect to the U.S. fittings supplied with AdvanTex Treatment Systems.*

Septic Tanks Used in AX20 Treatment Systems

Be sure that any septic tank used in an AX20 Treatment System meets the following conditions:

- The tank must be watertight and free of leaks.
- The tank must conform to the specifications of an authorized tank design for AdvanTex Systems. Call your local Dealer for specifics.
- The tank must meet all applicable regulatory requirements.

Standard System Components

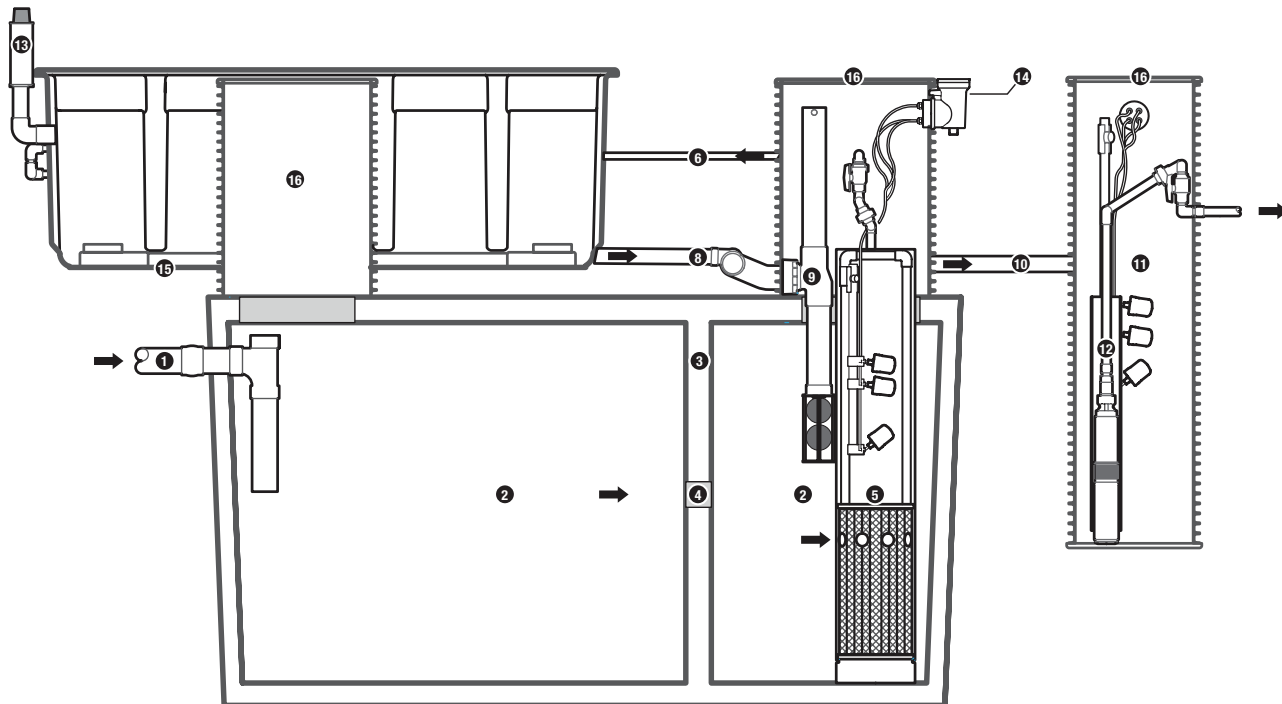
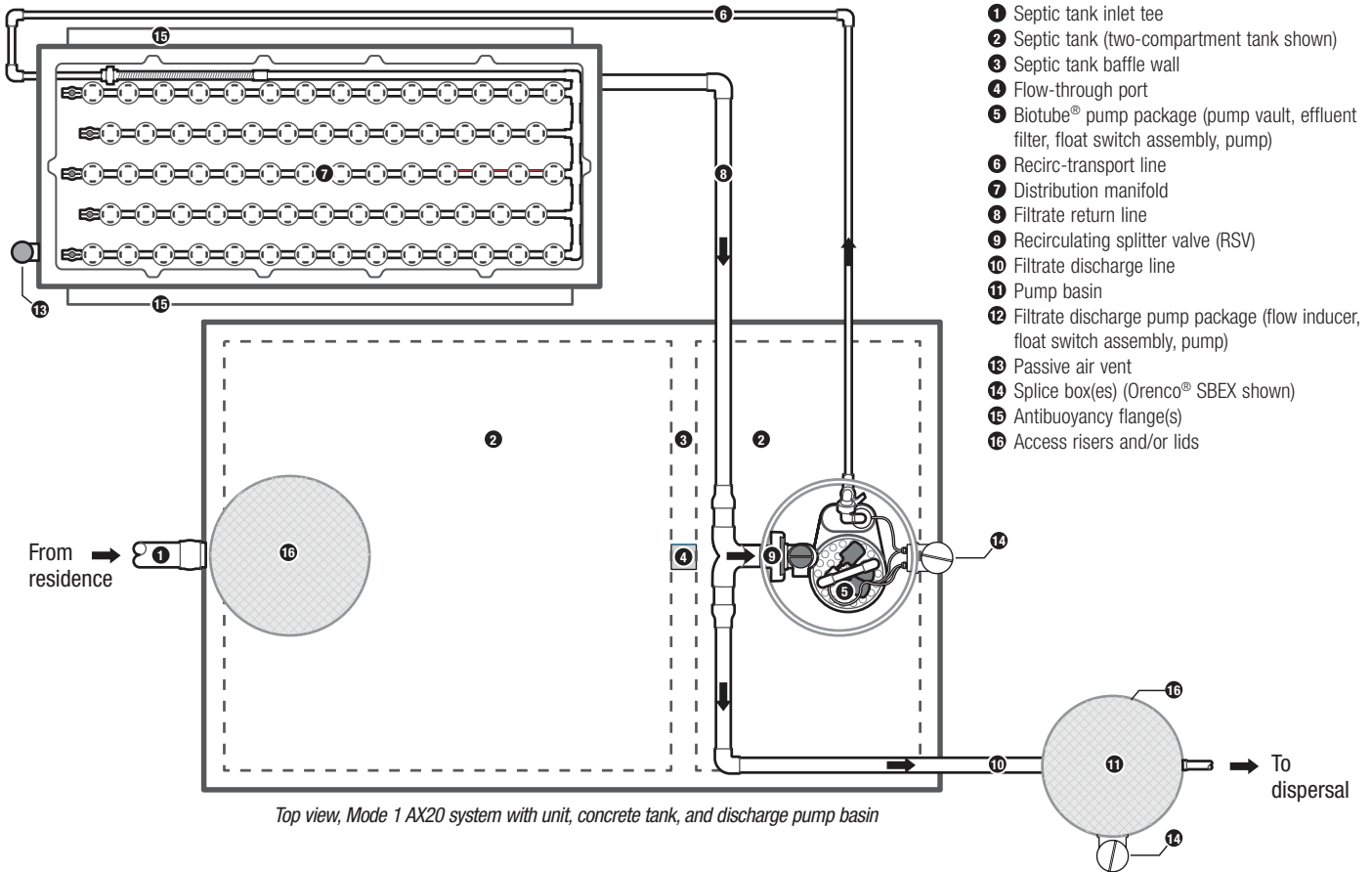

Installation Overview

Step 1: Review the site plan. If there is no site plan, draw up a plan including locations, elevations, and distances.

Step 2: Make the excavations for the septic tank, pump basin, and AX20 unit.



Note: You can make all of the excavations at the same time, or you can excavate separately for the unit, the basin, or both before installing them.

Step 3: Prep and set the septic tank and pump basin (if used) according to the manufacturer's instructions.



Note: If you are installing the pump basin in a separate installation, you can choose to prep and set it after testing the tank and adapters for watertightness.

Step 4: Install the tank adapters (if necessary) according to the manufacturer's instructions and install the access risers.

Step 5: Test the tank and the adapter seams for watertightness.



Key Point: The tank and tank-to-riser connections must pass this test before you connect the AX20.

Step 6: Prep and set the AX20 unit.

Step 7: Install the Biotube® Pump Package in the septic tank's second compartment (or the second tank, in two-tank systems).

Step 8: Install the discharge pumping equipment into the pump basin (if used).

Step 9: Install the recirculating splitter valve (RSV) in the septic tank and install the split flow tee between the septic tank, the AX20 unit, and the pump basin or final discharge.

Step 10: Connect the filtrate return line from the unit to the RSV.

Step 11: Connect the recirc transport line from the Biotube pump package to the distribution manifold in the AX20.

Step 12: Connect the filtrate discharge line.

Step 13: Install the passive air vent on the AX20 unit.

Step 14: Mount, wire, and test the control panel.

Step 15: Perform an operational test of the AdvanTex System.

Step 16: Backfill the installation and secure the AX20 lid and all access riser lids.

Installation Steps

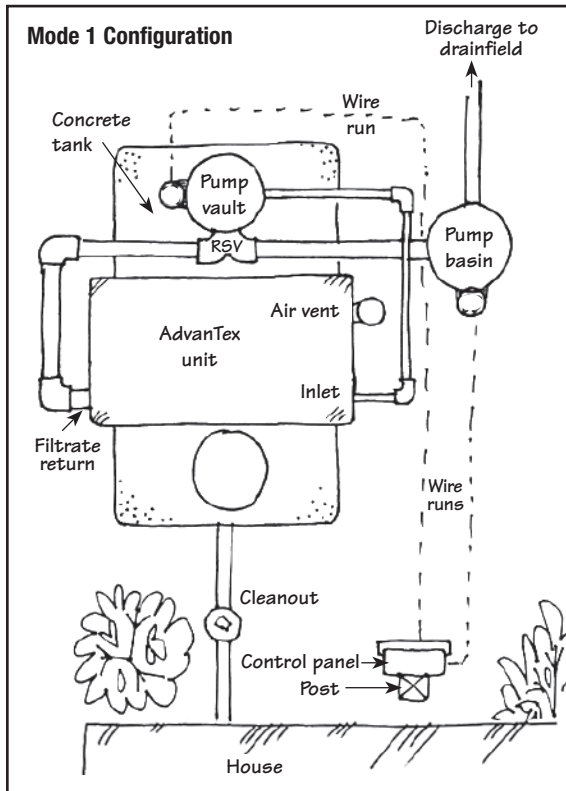

Sample sketch of a Mode 1 configuration system layout

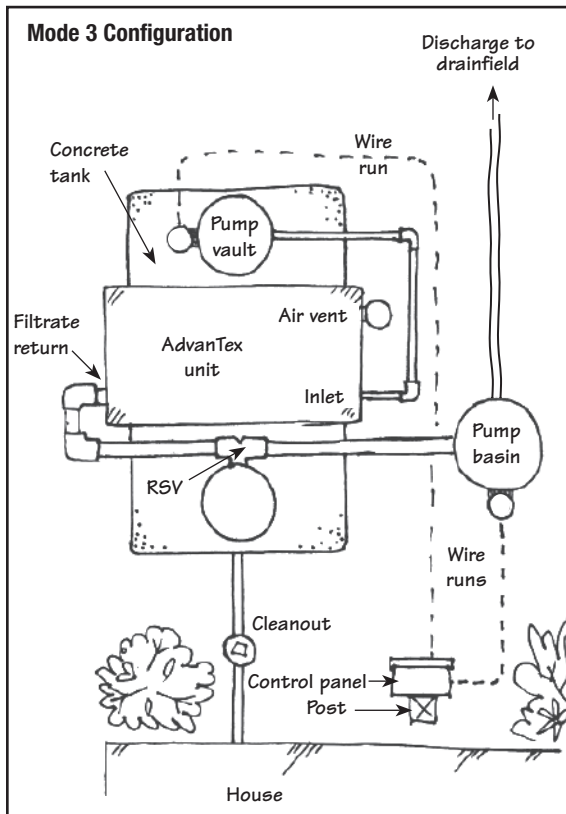

Sample sketch of a Mode 3 configuration system layout

Step 1: Review or Sketch Site Plan

Check the site plan for the specifics of your installation.



Key Points:

- If you're installing the AX20 unit more than 20 ft (6 m) from the septic tank, contact your Dealer for assistance.
- Confirm the treatment mode (Mode 1 or Mode 3) of the AdvanTex system you are installing before beginning the installation. The treatment mode is based on the system's nitrogen reduction requirements. For more information, contact your Dealer.

Step 1a: Detailed Site Plan Provided

Make sure that the site plan matches the site. If it doesn't, contact the designer or engineer before you schedule the installation.

Step 1b: Plan Of Limited Detail Or No Site Plan Provided

If you only have a plan of limited detail or no site plan, contact your Dealer for assistance.



Key Points:

- A minimum fall of ¼ inch per foot (20 mm per m or 2%) is required ...
 - ~ From the invert of the AX20 filtrate outlet to the invert of the RSV's inlet.
 - ~ From the invert of the RSV's outlet to the invert of the pump basin's inlet (on systems with pump basins).
- If you are using a concrete tank or you are using an Orenco fiberglass tank without a tank saddle, calculate how high the unit needs to sit above the inlet on the RSV split flow tee. Variables include:
 - ~ Length of the filtrate return line
 - ~ Type of tank being used
 - ~ Tank adapter style
 - ~ Elevation of the RSV penetration in the access riser
 - ~ Final grade of the site
- The bottom of the AX20 lid must sit at least 2 inches (50 mm) above final grade.
- An AX20 unit can be placed in several different positions in relation to the septic tank. If you have questions about unit placement, contact your Dealer before continuing.
- The filtrate outlet and the recirc inlet are typically installed on opposite sides of the AX20 unit.
- Sketch the exact positions of the system components, pipes, electrical conduits, etc. Account for current and likely future landscape features in the sketch. (For control panel installation, see EIN-CP-GEN-1, *Panel Installation*.)



Note: If you have any questions about the key points of planning this installation, please contact your Dealer.

Installation Steps

Step 2: Make Excavation(s)

Consider the necessary elevations, offsets, and grade requirements for the septic tank, AX20 unit, and discharge pump basin.

Step 2a: Excavate the septic tank hole. Follow the manufacturer's instructions.

- For Orenco fiberglass tanks, see NIN-TNK-1, *Fiberglass Tank Burial*.

Step 2b: Excavate the pump basin hole or discharge tank hole, if necessary. Follow the manufacturer's instructions.

- The pump basin can be placed in the same excavation as the septic tank, if there is enough room.
- If needed, you can make the pump basin excavation after you have prepped and set the tank.
- For Orenco PVC pump basins, see NIN-PB-1, *PVC Basin Installation*.



Key Point: A minimum fall of ¼ inch per foot (20 mm per m or 2%) is required from the invert of the AX20 filtrate outlet to the invert of the RSV's inlet and from the invert of the RSV's outlet to the invert of the pump basin's inlet or discharge tank's inlet.

Step 2c: Excavate the AX20 hole, if it's being installed in a separate excavation.

- If needed, you can make the AX20 excavation after you prep and set the tank and (if your system includes one) the pump basin.
- Excavate a hole 8.5 ft × 4.5 ft (without antifoatation flanges) or 6 ft (with antifoatation flanges) × up to 28 in. deep [2.6 m × 1.4 (or 1.8 m) × 0.7 m], depending on the fall necessary to meet requirements.
- For information on installation configurations or methods not included in this manual, contact your Dealer.



Key Points:

- A minimum fall of ¼ inch per foot (20 mm per m or 2%) is required from the invert of the AX20 filtrate outlet to the invert of the RSV's inlet.
- Allow at least 44 inches (1.1 m) between units in systems with multiple units.
- Antifoatation flanges are ...
 - ~ Recommended if the AX20 unit isn't attached directly to the tank.
 - ~ Required if groundwater could be present in the AX20 excavation at any time, or if surface runoff could fill the excavation at any time, resulting in a "bathtub" effect.
- If you have questions about the need for antifoatation flanges, contact your Designer or a qualified engineer.

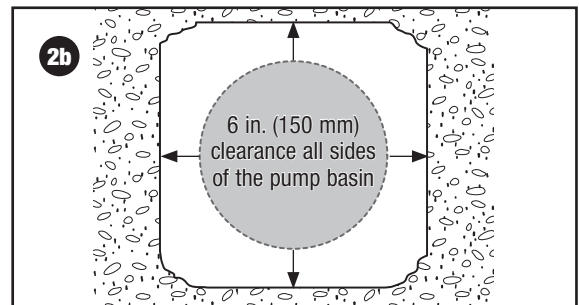

Example discharge basin hole (separate excavation)

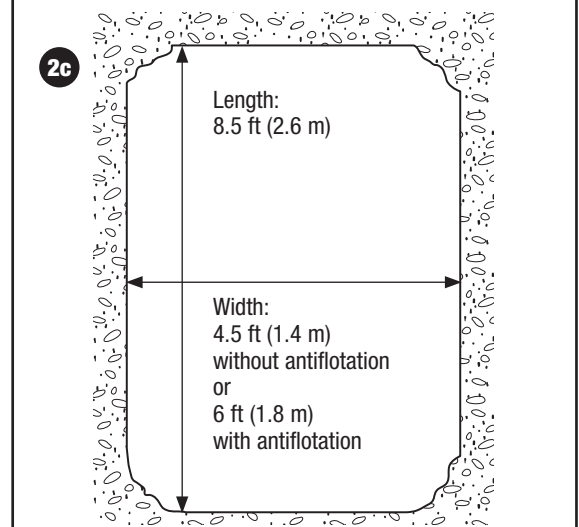

Excavation length and width for AdvanTex units (separate excavation)

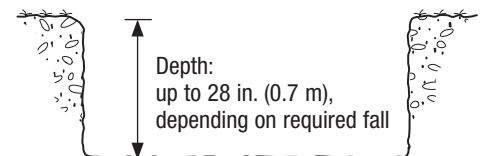

Excavation depth for AdvanTex units (separate excavation)

Installation Steps

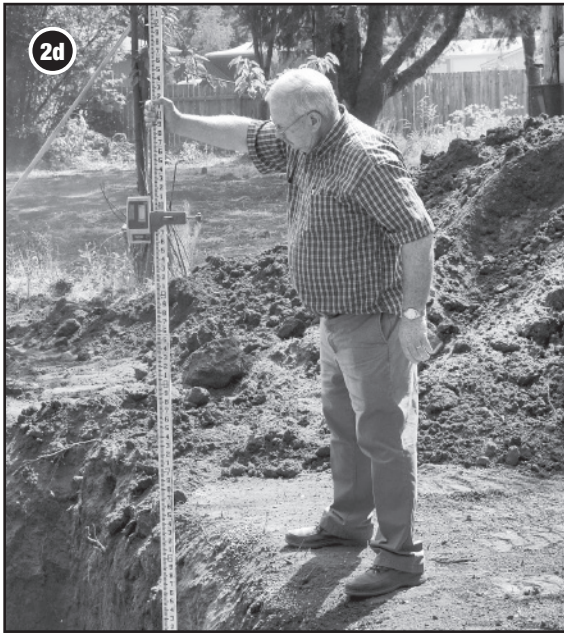

Step 2: Make Excavation(s), cont.

Step 2d: Make sure the bottom of each excavation is stable, smooth, level, and free of debris, rocks, and sharp objects.

Step 2e: Bed the tank and pump basin. Follow the manufacturers' instructions.

- For Orenco fiberglass tanks, see NIN-TNK-1, *Fiberglass Tank Burial*.
- For Orenco PVC pump basins, see NIN-PB-1, *PVC Basin Installation*.



Key Points:

- If the bottom is uneven or rocky, over-excavate the hole and lay a 4-inch (100-mm) bed of sand or pea gravel and compact it to make an even, smooth surface.
- For unstable soil (peat, quicksand, muck, soft or highly expansive clay, etc.), over-excavate the hole by 6 in. (150-mm) and set a firm, 6-in. (150-mm) compacted base of $\leq \frac{1}{2}$ - to $\leq \frac{3}{4}$ -in. (13- to 19-mm) aggregate or pea gravel.
- If you have doubts about the soil's stability, contact a qualified engineer or professional. For extremely unstable soil, contact a qualified engineer for recommendations on stabilizing the excavation before you continue.

Step 3: Prep and Set Septic Tank and Pump Basin

Step 3a: Prep and set the septic tank. Follow the manufacturer's instructions.

- For Orenco fiberglass tanks, see NIN-TNK-1, *Fiberglass Tank Burial*.



IMPORTANT: Take care to keep everyone clear of the excavation when placing the tank and pump basin!



Key Point: Set the tank at the correct depth to connect to the sewage inlet.

Step 3b: Prep and set the pump basin. Follow the manufacturer's instructions.

- If necessary, you can set and prep the pump basin at any time before prepping and setting the AX20 unit.
- For Orenco PVC pump basins, see NIN-PB-1, *PVC Basin Installation*.



IMPORTANT: It is critical for system operation that you set the basin with the RSV penetration correctly aligned and at the correct height!

Step 3c: Partially backfill the septic tank (and pump basin, if it is in the same excavation). Follow the manufacturers' instructions.

- For Orenco fiberglass tanks, see NIN-TNK-1, *Fiberglass Tank Burial*.
- For Orenco PVC pump basins, see NIN-PB-1, *PVC Basin Installation*.



Key Point: If the tank and basin are in the same excavation, only backfill around the pump basin to just below the bottom of the basin inlet hole until you've plumbed the basin.

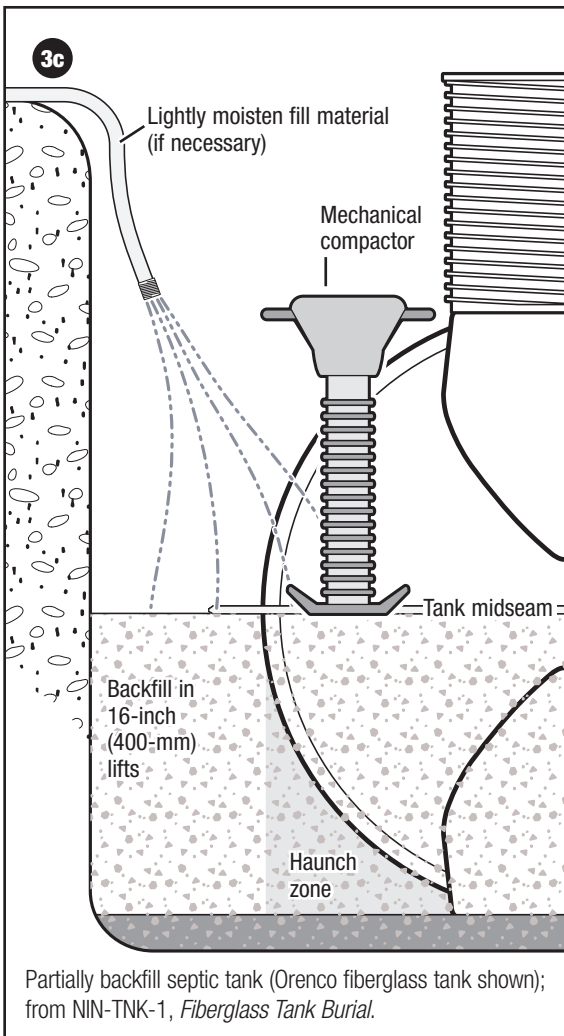

Installation Steps

Step 4: Install Tank Adapters and Risers (If Needed)

Step 4a: Install the tank adapters if they haven't been installed. Follow the manufacturer's instructions.

- For Orenco PRTA24 or PRTA30 Tank Adapters, see NIN-TA-PRTA-2, *PRTA24 and PRTA30 Tank Adapter*.
- For Orenco RRFTA or RRFTA30 Tank Adapters, see NIN-TA-RRFTA-1, *RRFTA and RRFTA30 Tank Adapter*.
- For Orenco FRTA30-FRP Tank Adapters, see NIN-TA-FRTA-1, *FRTA30-FRP Tank Adapter*.

Step 4b: Install the access risers, if they haven't been installed, as well as any necessary grommets and splice boxes.

- For installing grommets in access risers and installing risers onto Orenco tank adapters, see NIN-RLA-RR-1, *PVC Riser Installation*.
- For Orenco external splice boxes, see NIN-SB-SBEX-1, *External Splice Box*.
- For Orenco internal splice boxes, see NIN-SB-SB-1, *Internal Splice Box*.



Key Points:

- Watertight seams and penetrations are critical for proper performance.
- Before installing the risers, make sure that ...
 - ~ All risers are the correct height — the recommended riser height is 2 inches (50 mm) above final grade.
 - ~ All riser penetrations are at the correct height for the connections.
 - ~ The RS3 flanged coupling is installed in the correct riser and the riser with the RS3 flanged coupling is being installed over the correct tank access hole. (See NIN-RSV-3, *Recirculating Splitter Valve*.)
 - ~ All riser penetrations are aligned correctly.
- After installing the risers, make sure that ...
 - ~ All adhesive seams are free of voids, with smooth, continuous fillets.
 - ~ The adhesive is set before continuing.

Step 5: Test Tank and Adapter Seams for Watertightness

Step 5a: Test the tank's watertightness. Follow the manufacturer's instructions.

- Some manufacturers require you to partially or fully backfill around the tank before testing for watertightness.

Step 5b: Test the tank-to-riser adapter seams for watertightness.

- Use NIN-RLA-RR-1, *PVC Riser Installation* instructions to test the seams between the access riser, tank adapter, and tank for watertightness.



Key Points:

- The seams between the access riser, tank adapter, and tank must all pass the watertightness test before you continue.
- Follow all applicable regulations for watertightness testing.

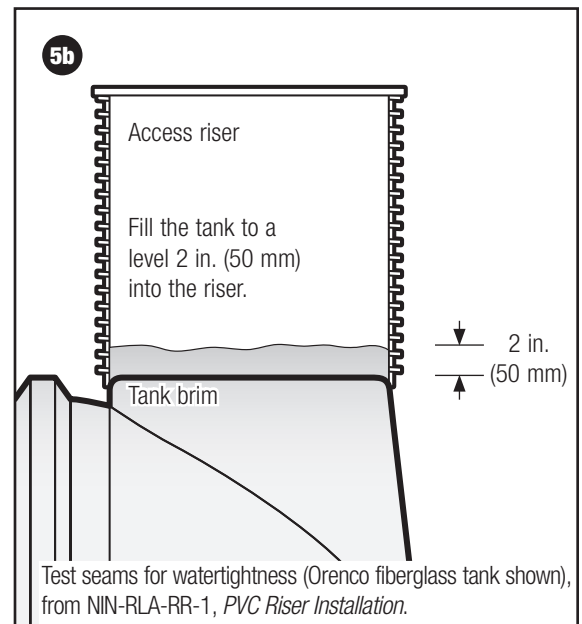

Installation Steps

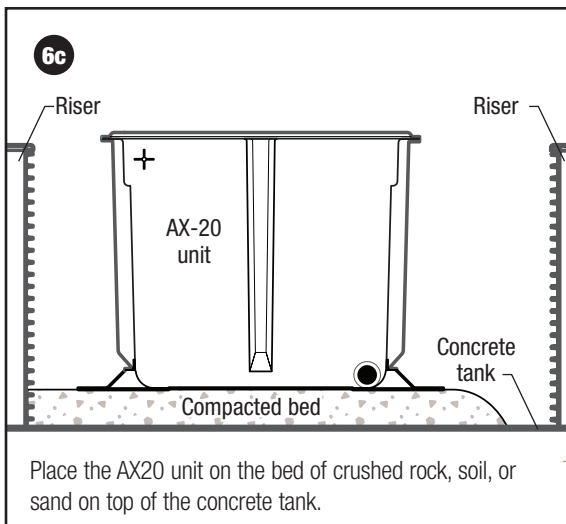

Step 6: Prep and Set AX20 Unit

To prep and set the AX20 unit, find the correct sub-step below. If you don't see your application listed, stop and contact your Dealer before continuing.

- Attaching antiflotation flanges to the unit ... see Step 6a.
- Setting the unit in its own excavation ... see Step 6b.
- Setting the unit over the tank, unattached ... see Step 6c.
- Attaching the unit to the top of an Orenco fiberglass tank ... see Step 6d.



Key Points:

- For all AX20 installations, a minimum fall of ¼ in. per ft (20 mm per m or 2%) is required from the invert of the AX20's filtrate outlet to the invert of the RSV's inlet.
- The AX20 lid's bottom must be at least 2 in. (50 mm) above finished grade.
- An AX20 weighs about 350 lb (160 kg) dry.



IMPORTANT:

- Always make sure the lid is bolted down before lifting the AX20 unit.
- Orenco strongly recommends using an excavator and lifting straps to lift and move the AX20 unit.
- Never wrap lifting straps around the antiflotation flanges. See Photo 6b, "Lift the AX20 unit," for the correct way to lift the unit.
- Keep everyone clear of the excavation when placing the unit.

Step 6a: Attaching Antiflotation Flanges To The Unit

1. Set the unit on a raised surface with access to the unit's underside.
2. Align the flanges with the pre-drilled brackets on the bottom of the unit.
3. Use the bracket holes as pilots to drill 17/64-in. (7-mm) holes in the flanges.
4. Attach the flanges to the brackets with the included hardware.

Step 6b: Setting The Unit In Its Own Excavation

- 1: Make sure the AX20 unit's lid is bolted down.
- 2: Lift and lower the unit into position.
- 3: Make sure the unit is aligned correctly and that it is level.

Step 6c: Setting The Unit Over The Tank, Unattached

- 1: Follow the tank manufacturer's instructions for backfilling the tank.
 - For Orenco fiberglass tanks, see NIN-TNK-1, *Fiberglass Tank Burial*.
- 2: Place and compact a bed of crushed rock, soil, or sand on top of the tank.
 - The bed has to be thick enough to provide the correct fall from the invert of the AX20 filtrate outlet to the invert of the RSV's inlet.
- 3: Make sure the AX20 unit's lid is bolted down.
4. Lift and lower the AX20 unit into position.
- 5: Make sure the unit is aligned correctly and that it is level.

Installation Steps

Step 6: Prep and Set AX20 Unit, cont.

Step 6d: Attaching The Unit To An Orenco Fiberglass Tank

1: Install the tank saddles if they aren't already installed on the tank.

- For Orenco tank saddles, see NIN-SAD-2, *Two-Piece Fiberglass Tank Saddle Installation*.

2: Set the unit on a raised surface with access to the unit's bottom.

3: Sand the unit's bottom surface where it will rest on the saddles.

4: Wipe the unit's and saddles' bonding surfaces with acetone and a clean cloth.

5: Apply a bead of methacrylate adhesive to the saddles' bonding surfaces.

6: Lift and lower the AX20 unit into position.

7: Make sure the unit is level and fully seated on the saddles.

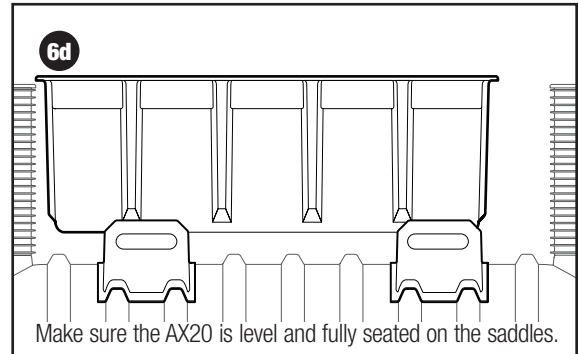
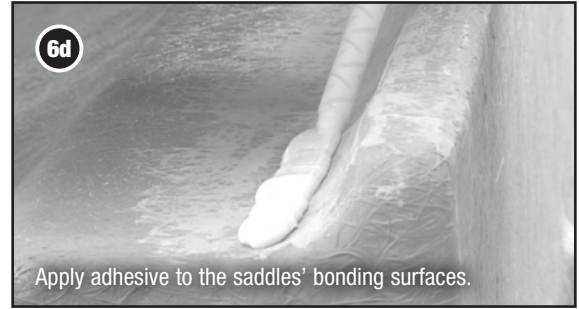

Step 7: Install Pump Package in Septic Tank

Install the Biotube® pump package components in the septic tank.

Step 7a: Install the pump vault.

- For PVU and PV series pump vaults, see NIN-PVU-1, *Biotube Pump Vault Installation*.

Step 7b: Install the pump and discharge plumbing assembly.

- For HV-style discharge plumbing, see NIN-HV-1, *Pump and Discharge Plumbing*.

Step 7c: Install the float switch assembly.

- For installing float switch assemblies, see NIN-MF-1, *Float Switch Assembly*.

Step 8: Install Pump Package in Pump Basin

If your system includes a pump basin, install the pump package now.



Key Point: A minimum fall of ¼ inch per foot (20 mm per m or 2%) is required from the invert of the RSV's outlet to the invert of the pump basin's inlet.

Step 8a: Install the pump and discharge plumbing assembly.

- For HV-style discharge plumbing, see NIN-HV-1, *Pump and Discharge Plumbing*.

Step 8b: Install the float switch assembly.

- For float switch assemblies, see NIN-MF-1, *Float Switch Assembly*.

Step 8c: After you've installed the pump package components, test the pump basin for watertightness.

- For Orenco PVC pump basins, see NIN-PB-1, *PVC Basin Installation*.

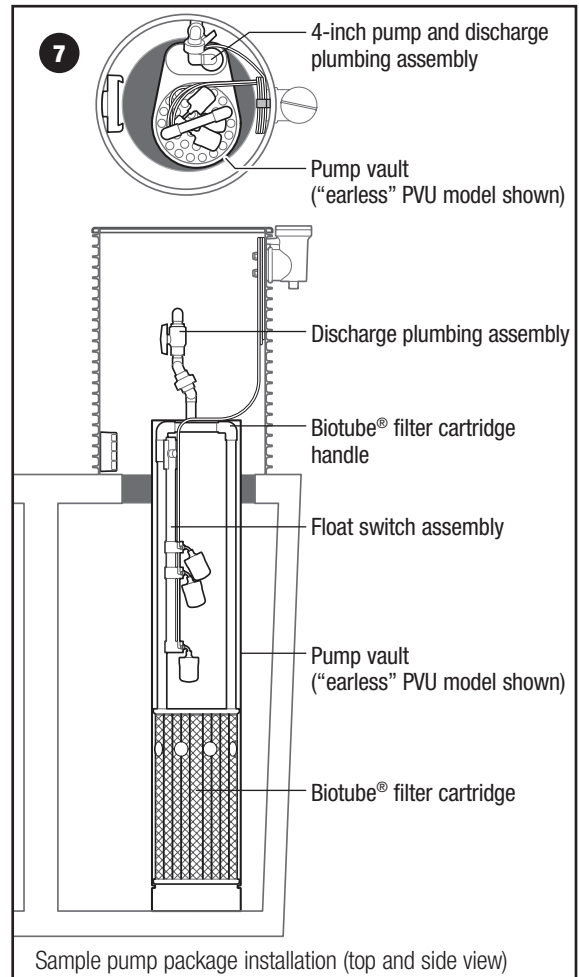

Installation Steps

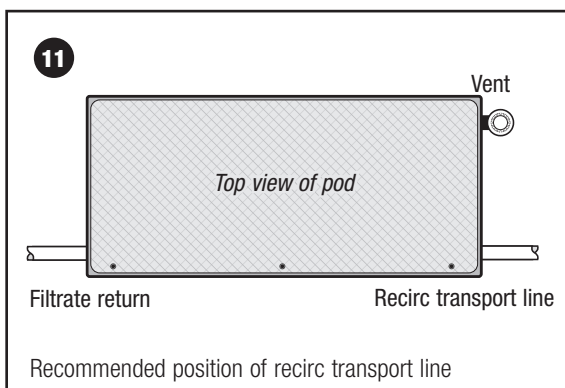
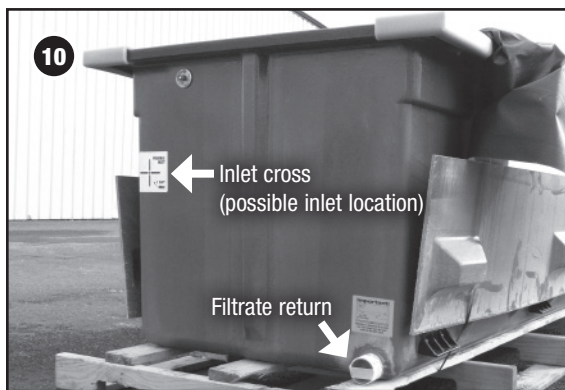
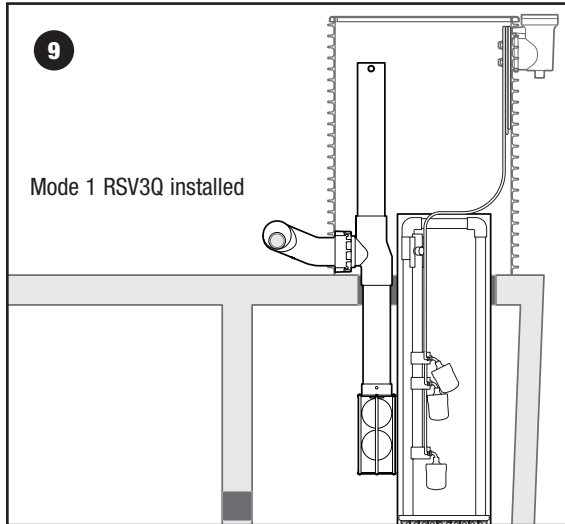

Step 9: Install Recirculating Splitter Valve (RSV)

Install the RSV in the first septic tank's second compartment or in the second septic tank's inlet riser (Mode 1), or in the first septic tank's inlet riser (Mode 3).

- If you are unfamiliar with the terms "Mode 1" and "Mode 3," or if the design doesn't state the mode for the system, stop and contact the Designer or the Dealer.
- For RSVs in residential AX20 applications, see NIN-RSV-3, *Recirculating Splitter Valve Installation*.
- To determine the correct stinger length, see NIN-ATX-DA-1, *Float Switch and RSV Settings*.
- For RSVs in commercial AX20 applications, contact your Dealer.



IMPORTANT:

- It is critical for system operation that ...
 - ~ The split flow tee is correctly aligned and at the correct height!
 - ~ The eccentric couplings are installed with their offset openings at the invert of the split flow tee.
 - ~ The stinger length is correct.
- Use an all-purpose ABS/PVC transition cement to join ABS and PVC parts.

Step 10: Connect Filtrate Return Line

Step 10a: Dry fit the filtrate return plumbing between the filtrate return on the AX20 unit and the split-flow tee on the RSV.

- Use 2-inch nominal (50-mm DN) PVC pipe and fittings as needed.



Key Point: Maintain a minimum fall of 1/4 inch per foot (20 mm per m or 2%) from the invert of the AX20 filtrate outlet to the invert of the RSV's inlet.

Step 10b: Mark the correct lengths and fall angles on the pipe and fittings.

Step 10c: Disassemble the plumbing and adjust as needed for good fit and fall.

Step 10d: Glue and refit the filtrate return line's pipe sections and fittings.



IMPORTANT: Use an all-purpose ABS/PVC transition cement to join ABS and PVC parts.

Step 11: Connect Recirc Transport Line

Step 11a: Dry fit the recirc transport line plumbing between the septic tank's outlet and the inlet of the AX20's distribution manifold.

- Use 2-inch nominal (50-mm DN) PVC pipe and fittings as needed.

Step 11b: Mark the correct lengths on the pipe and fittings.

Step 11c: Disassemble the plumbing and adjust as needed for good fit.

Step 11d: Glue and refit the recirc transport line's pipe sections and fittings.

Installation Steps

Step 12: Connect Filtrate Discharge Line

Step 12a: Dry fit the filtrate discharge plumbing between the RSV's split-flow tee and the transport line to dispersal or the pump basin's inlet (if equipped).



Key Point: Maintain a minimum fall of ¼ inch per foot (20 mm per m or 2%) from the invert of the RSV's outlet to final dispersal or the invert of the pump basin's inlet (if equipped).

Step 12b: Mark the correct lengths and fall angles on the pipe and fittings.

Step 12c: Disassemble the plumbing and adjust as needed for good fit and fall.

Step 12d: Glue and refit the filtrate discharge line's pipe sections and fittings.



IMPORTANT: Use an all-purpose ABS/PVC transition cement to join ABS and PVC parts.



Step 13: Install Passive Air Vent

Use 2-inch (50 mm) PVC pipe to connect the unit's passive air vent to the 2-inch (50 mm) vent fitting that protrudes from the side of the AX20 unit.

- The air vent can be installed up to 20 ft (6 m) away from the AX20 unit, preferably near a wall or other location that will protect it from damage.
- The air vent can be hidden by shrubbery or landscaping, and it can be painted to better blend in with landscaping.



Key Point: Make sure that ...

- ~ The vent line slopes back toward the unit a minimum of ¼ inch per foot (20 mm per m) for proper drainage.
- ~ There are no "bellies" in the line that can collect water.
- ~ The vent's top is a minimum of 3 inches (75 mm) above final grade.

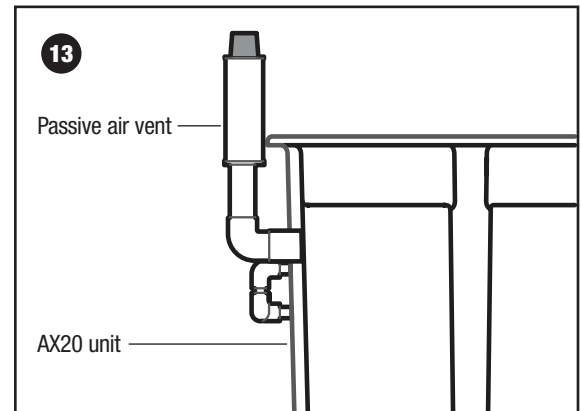

Step 14: Mount and Wire Control Panel



Note: Installation instructions, schematics, and wiring diagrams for the specific treatment system are included with each panel. If any of these are missing, contact your Dealer for a replacement.

Step 14a: Mount the panel using the instructions that came with it.



IMPORTANT:

- DO NOT mount the control panel on an exterior wall other than a garage or shop wall! The motor contactor makes a sound while engaging and disengaging that can be disruptive to residents.
- This step should be performed by a licensed and qualified electrician.



Key Points:

- Follow all applicable regulations for placement of the control panel.
- Mount the panel in a service-friendly location within sight of the tank.

Installation Steps

Step 14: Mount and Wire Control Panel, cont.

Step 14b: Route and install any necessary electrical conduit.

Step 14c: Route wires and connect the panel, pump, float switches, and other equipment shown in the instructions and schematics into the control panel.



IMPORTANT: Follow all applicable regulations and electrical codes.



Key Points:

- Use watertight wire connectors to avoid electrical shorts and other issues.
- Be sure to seal the conduit at the control panel and at the splice box with UL-listed sealing foam, putty, or silicone sealant.

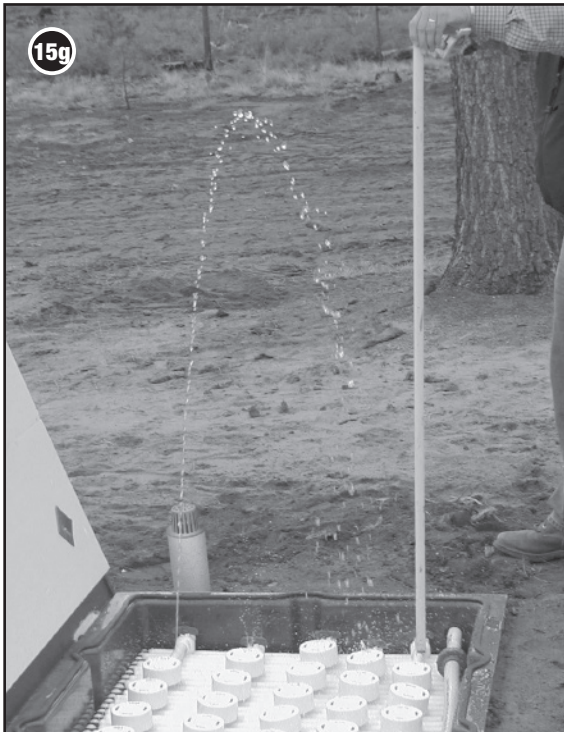

Step 15: Perform Operational Test



IMPORTANT:

- Before using a generator to operate one or more pumps, contact your Dealer to make sure it can supply sufficient starting amperage to the pump(s).
- Always make sure there is enough water in the septic tank to safely run the pump — at least 4 inches (100 mm) above the bottom float switch.
- For Mode 1B and Mode 3B systems, fill the pump basin with water until the water level is just under the lowest float.

Step 15a: Disconnect the manifold union.

Step 15b: Toggle the recirc pump “AUTO/OFF/MAN” switch to “MAN” for 5-10 seconds to flush any debris out of the transport line.

Step 15c: Reconnect the manifold union and hand-tighten it.

Step 15d: Open all of the ball valves on the distribution manifold laterals.

Step 15e: Toggle the recirc pump “AUTO/OFF/MAN” switch to “MAN” for 5-10 seconds to flush any debris out of the manifolds.

Step 15f: Close the ball valves.

Step 15g: Remove orifice shields from several nozzles and use a tape measure to find out the squirt height from each.

- The squirt height should measure approximately 3-5 ft (0.9-1.5 m).
- If the squirt height isn't at least 3 feet (0.9 m),
 - ~ Check for debris, breaks, or closed valves.
 - ~ Check the required voltage on the pump to be sure the pump has enough power.
- If the system doesn't pressurize correctly, contact your Dealer.

Step 15h: Return the recirc pump “AUTO/OFF/MAN” switch to “AUTO.”

Step 15i: If necessary, refill the tank past the inlet holes on the pump vault.

Installation Steps

Step 16: Backfill Installation



Key Points:

- Do not alter the slope of pipes during backfilling. Brace them or place them on compacted beds and then carefully fill around them.
- Before backfilling, make sure all lids are bolted down.

Step 16a: Finish backfilling the tank excavation if it isn't done yet. Follow the manufacturer's instructions.

- For Orenco fiberglass tanks, see NIN-TNK-1, *Fiberglass Tank Burial*.



IMPORTANT: Attaching the AX20 unit to an Orenco fiberglass tank adds to the tank's buoyancy. In noncohesive soils,* this means a concrete antifloatation collar has to be installed around the tank's mid-seam. Contact your Dealer or a qualified engineer if you are unsure whether a concrete collar is needed.

Step 16b: Backfill the pump basin if it hasn't been done yet.

- For Orenco PVC pump basins, see NIN-PB-1, *PVC Basin Installation*.

Step 16c: Backfill and compact around the AX20 unit in 12-in. (300-mm) lifts.



Key Points:

- Do not use native material to backfill if it is primarily sand; very soft or highly expansive clay; or if it contains debris, large (> ¾-in. or 19-mm) rocks, sharp rocks, peat, or muck. In these cases, use ≤ ¾-in. (≤ 19-mm) rounded gravel, crushed stone, or pea gravel as fill material. This material should be washed, free-flowing, and free of debris.
- In noncohesive soils* with high seasonal water tables, use ¾-inch crushed rock as the backfill material.
- Do not backfill with sand.

Step 16d: Compact the fill thoroughly with a mechanical compactor.



Key Points:

- The bottom of the AX20 lid should sit 2 inches (50 mm) above final grade.

Step 16e: Close and secure the AX20 unit's lid.

Step 16f: Secure the access lids on the tank and pump basin (if used).

Step 16g: Before the system goes into use, contact the system's Service Provider and complete the system start-up together per AIM-OM-ATX-1, *AdvanTex O&M Manual: Start-Up and Routine Maintenance*.

* As described in OSHA Standards (29 CFR, Part 1926, Subpart P, Appendix A), noncohesive soils or granular soils include gravel, sand, or silt with little or no clay content. Granular soil cannot be molded when moist and crumbles easily when dry. Cohesive soils include clayey silt, sandy clay, silty clay, clay, and organic clay. Cohesive soil does not crumble, can be excavated with vertical sideslopes, is hard to break up when dry, and when moist, can be rolled into threads without crumbling. For example, if at least a 2-inch (51-mm) length of 1/8-inch (3-mm) thread can be held on one end without tearing, the soil is cohesive.



Installation Manual

AdvanTex[®] AX20 Treatment Systems *Residential Applications*



AdvanTex Treatment System AXN
Models meet the requirements of NSF/ANSI
Standard 40 for Class I Systems.



Orenco[®]

Orenco Systems[®], Incorporated

1-800-348-9843

+1-541-459-4449

www.orenco.com

NIM-ATX-AX-1
Rev. 5.0, © 03/17
Orenco Systems[®], Inc.